



SEMITOP[®] 2

IGBT Module

SK20GH065

Preliminary Data

Features

- Compact design
- One screw mounting
- Heat transfer and isolation through direct copper bonded aluminium oxide ceramic (DCB)
- N-channel homogeneous Silicon structure (NPT-NonPunchThrough IGBT)
- High short circuit capability
- Low tail current with low temperature dependence
- UL recognized, file no E63532

Typical Applications*

- Switching (not for linear use)
- Inverter
- Switched mode power supplies
- UPS

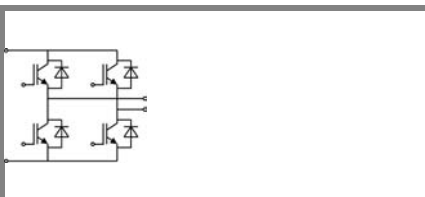

GH

Absolute Maximum Ratings		$T_s = 25\text{ °C}$, unless otherwise specified			
Symbol	Conditions	Values			Units
IGBT					
V_{CES}	$T_j = 25\text{ °C}$	600			V
I_C	$T_j = 125\text{ °C}$	$T_s = 25\text{ °C}$	24		A
		$T_s = 80\text{ °C}$	18		A
I_{CRM}	$I_{CRM} = 2 \times I_{Cnom}$	40			A
V_{GES}		± 20			V
t_{psc}	$V_{CC} = 300\text{ V}; V_{GE} \leq 20\text{ V}; T_j = 125\text{ °C}$ $V_{CES} < 600\text{ V}$	10			µs
Inverse Diode					
I_F	$T_j = 125\text{ °C}$	$T_s = 25\text{ °C}$	25		A
		$T_s = 80\text{ °C}$	18		A
I_{FRM}	$I_{FRM} = 2 \times I_{Fnom}$	40			A
Module					
$I_{t(RMS)}$					A
T_{vj}		-40 ... +150			°C
T_{stg}		-40 ... +125			°C
V_{isol}	AC, 1 min.	2500			V

Characteristics		$T_s = 25\text{ °C}$, unless otherwise specified			
Symbol	Conditions	min.	typ.	max.	Units
IGBT					
$V_{GE(th)}$	$V_{GE} = V_{CE}, I_C = 0,5\text{ mA}$	3	4	5	V
I_{CES}	$V_{GE} = 0\text{ V}, V_{CE} = V_{CES}, T_j = 25\text{ °C}$	0,07			mA
I_{GES}	$V_{CE} = 0\text{ V}, V_{GE} = 20\text{ V}, T_j = 25\text{ °C}$	120			nA
V_{CE0}		$T_j = 25\text{ °C}$	1		V
		$T_j = 125\text{ °C}$	1,1		V
r_{CE}	$V_{GE} = 15\text{ V}$	$T_j = 25\text{ °C}$			mΩ
		$T_j = 125\text{ °C}$	55		mΩ
$V_{CE(sat)}$	$I_{Cnom} = 20\text{ A}, V_{GE} = 15\text{ V}$	$T_j = 25\text{ °C}_{chiplev.}$	2		V
		$T_j = 125\text{ °C}_{chiplev.}$	2,2		V
C_{res}	$V_{CE} = 25, V_{GE} = 0\text{ V}, f = 1\text{ MHz}$	1,1		nF	
C_{oes}		0,107		nF	
C_{res}		0,063		nF	
$t_{d(on)}$	$R_{Gon} = 30\text{ }\Omega$	$V_{CC} = 300\text{ V}$ $I_C = 20\text{ A}$	21		ns
t_r			28		ns
E_{on}	$R_{Goff} = 30\text{ }\Omega$	$T_j = 125\text{ °C}$ $V_{GE} = \pm 15\text{ V}$	0,6		mJ
$t_{d(off)}$			170		ns
t_f			20		ns
E_{off}			0,4		mJ
$R_{th(j-s)}$	per IGBT	1,7			K/W

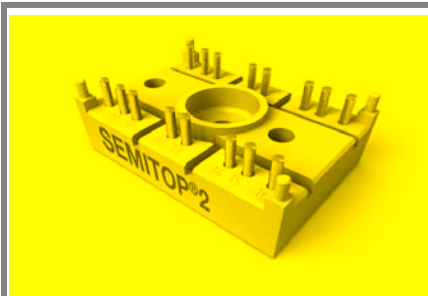

SEMITOP[®] 2

IGBT Module

SK20GH065

Preliminary Data

Features

- Compact design
- One screw mounting
- Heat transfer and isolation through direct copper bonded aluminium oxide ceramic (DCB)
- N-channel homogeneous Silicon structure (NPT-NonPunchThrough IGBT)
- High short circuit capability
- Low tail current with low temperature dependence
- UL recognized, file no E63532

Typical Applications*

- Switching (not for linear use)
- Inverter
- Switched mode power supplies
- UPS

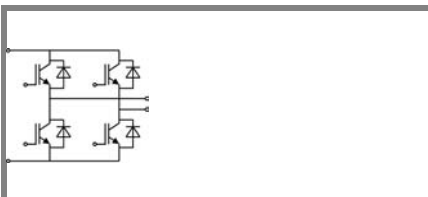

GH

Characteristics

Symbol	Conditions	min.	typ.	max.	Units
Inverse Diode					
$V_F = V_{EC}$	$I_{Fnom} = 20 \text{ A}; V_{GE} = 0 \text{ V}$		$T_j = 25 \text{ }^\circ\text{C}_{chiplev.}$	1,6	V
			$T_j = 125 \text{ }^\circ\text{C}_{chiplev.}$	1,6	V
V_{F0}			$T_j = 25 \text{ }^\circ\text{C}$		V
			$T_j = 125 \text{ }^\circ\text{C}$	0,9	V
r_F			$T_j = 25 \text{ }^\circ\text{C}$	30	mΩ
			$T_j = 125 \text{ }^\circ\text{C}$	33	mΩ
I_{RRM}	$I_F = \text{A}$				A
Q_{rr}					μC
E_{rr}	$V_R = 300\text{V}$				mJ
$R_{th(j-s)D}$	per diode			1,7	K/W
M_s	to heat sink			2	Nm
w			19		g

This is an electrostatic discharge sensitive device (ESDS), international standard IEC 60747-1, Chapter IX.

* The specifications of our components may not be considered as an assurance of component characteristics. Components have to be tested for the respective application. Adjustments may be necessary. The use of SEMIKRON products in life support appliances and systems is subject to prior specification and written approval by SEMIKRON. We therefore strongly recommend prior consultation of our personal.

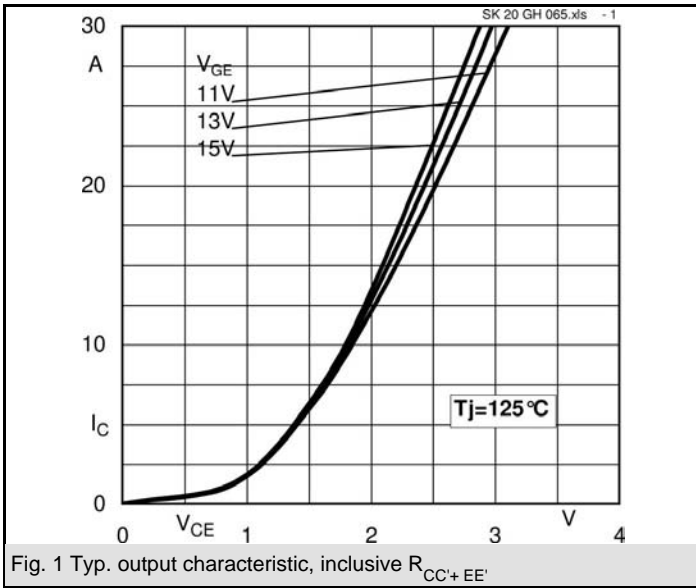

Fig. 1 Typ. output characteristic, inclusive $R_{CC+EE'}$

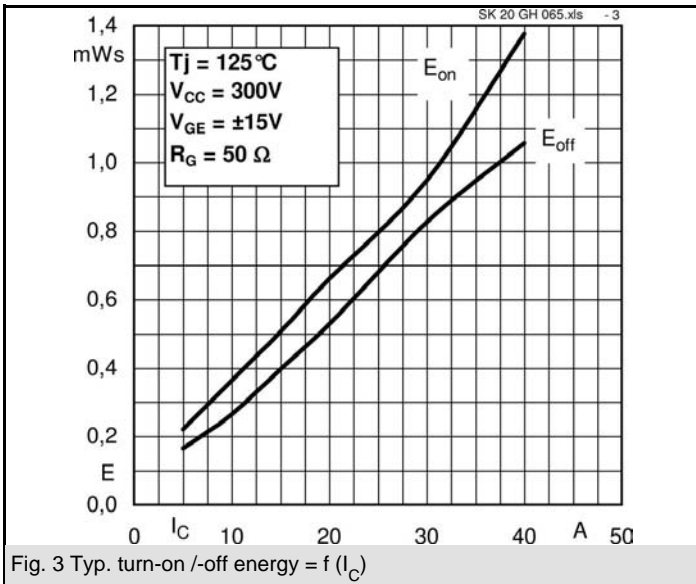

Fig. 3 Typ. turn-on /-off energy = $f(I_C)$

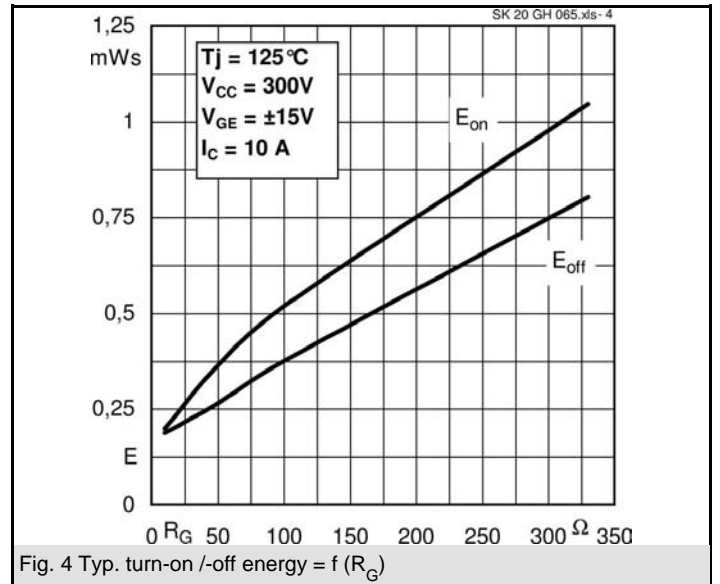

Fig. 4 Typ. turn-on /-off energy = $f(R_G)$

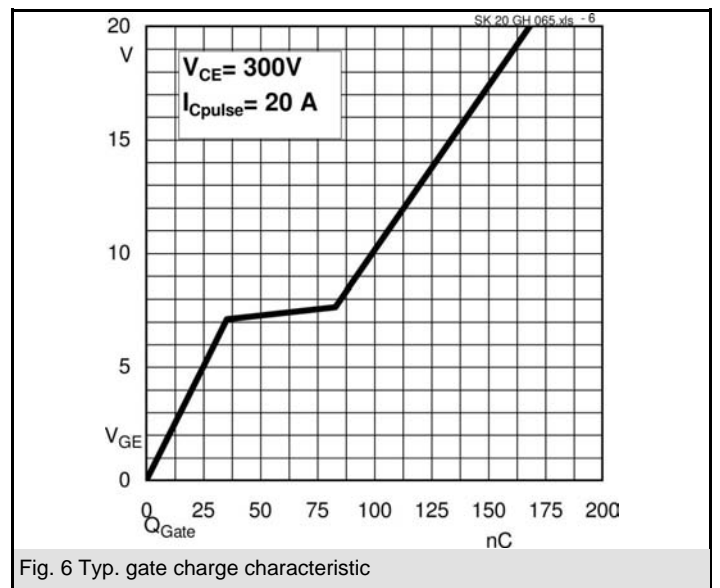
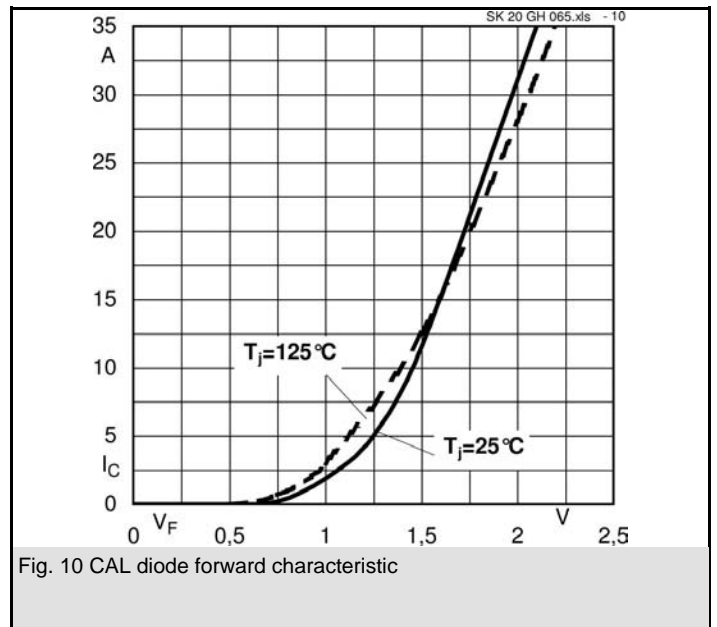
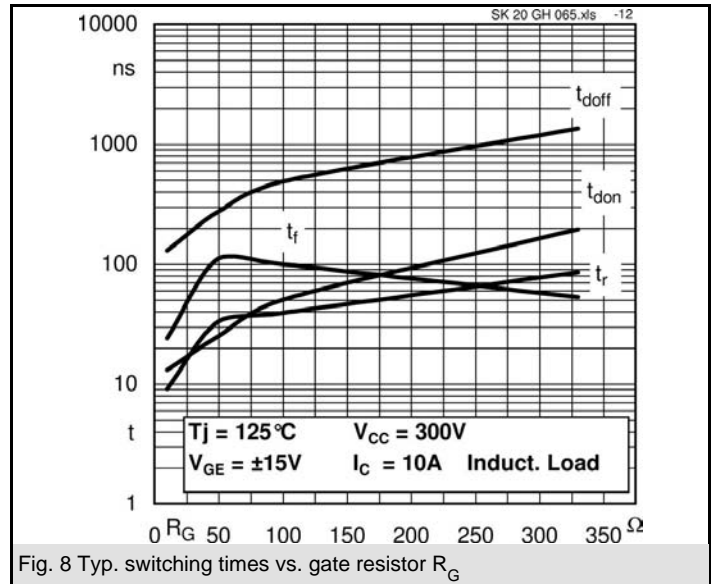
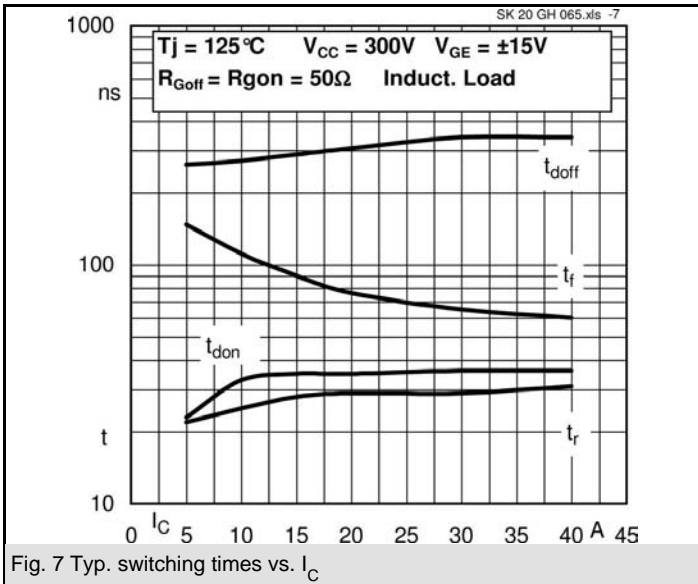
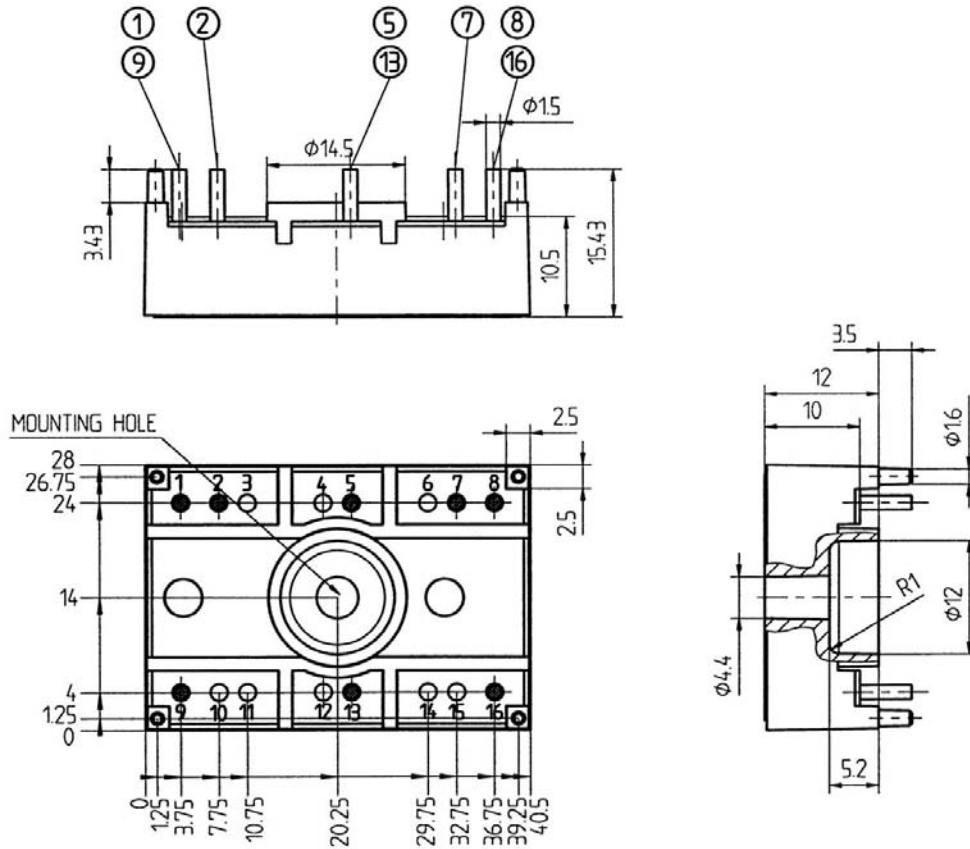
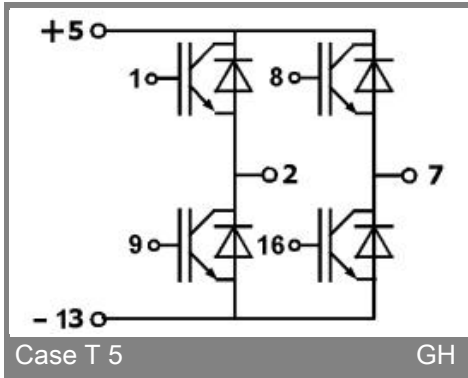

Fig. 6 Typ. gate charge characteristic





Case T5 (Suggested hole diameter, in the PCB, for solder pins and plastic mounting pins: 2mm)



Case T 5

GH